

dyson airblade

The fastest, most hygienic hand dryer.





JAMES DYSON THINKS EVERYDAY TECHNOLOGY SHOULD WORK PROPERLY.



THE DYSON RESEARCH, DESIGN AND DEVELOPMENT FACILITY IN WILTSHIRE, UK.



DYSON ENGINEERS WORK IN A BUILDING THE SIZE OF 30 TENNIS COURTS.



THE AIRBLADE™ HAND DRYER IS ENGINEERED TO REDUCE NOISE GENERATED IN USE.

Dyson is about new technology

Its founder and chairman is James Dyson, a British engineer. He spent five years battling against the odds to develop and manufacture the first vacuum cleaner with constant suction.

Today, Dyson vacuum cleaners are sold in 45 countries, including the UK, US, Australia and New Zealand – where it's market-leader. James works with 550 like-minded engineers and scientists at the Dyson research, design and development centre in the UK.

Together, they find out why technology fails and discover new ways to overcome problems. Every year, Dyson re-invests half its profits developing new ideas. New thinking.

Like an entirely new type of hand dryer technology.

dyson **airblade**

Hand drying, re-engineered

The Airblade™ hand dryer wipes hands dry with a high-velocity sheet of air in just 10 seconds.

It's fast and hygienic. It uses less energy than warm air hand dryers, so your business can reduce costs. And it's better for the environment.

Why the Airblade™ hand dryer is different



Dry hands in 10 seconds

The motor spins 88,000 times a minute creating pressurised air that's channelled through an aperture the width of an eyelash to scrape water from hands.

Dyson Digital Motor

Developed by Dyson engineers, it has only three moving parts and does away with the carbon brushes and slip rings that wear out in other hand dryers. Fewer moving parts make it more reliable.

Only clean air

Before being blown onto hands, the air passes through a HEPA filter, removing 99.9% of the bacteria in washroom air.

Automatic

It starts and stops when users insert or remove their hands. There's no need to touch anything.

Energy efficient

The Airblade™ hand dryer uses up to 75% less energy than warm air hand dryers. It can also help your business reduce its impact on the environment. It achieves this in three ways:

Fast

Because it dries hands in just 10 seconds, the Airblade™ hand dryer doesn't run for long. Sensors detect when hands are removed, switching it off to prevent wasting energy.

No Energy-Hungry Heating Element

The Airblade™ hand dryer doesn't rely on warm air to dry hands. So it doesn't need to power an energy-hungry heating element.

Dyson Digital Motor

The Dyson Digital Motor is a long-life, highly efficient electric motor. It doesn't rely on the carbon brushes or commutators used in conventional electric motors. As a result, it can turn incredibly fast and there is nothing to wear out. That's how it can generate the high velocity air required to dry hands in such a short time.

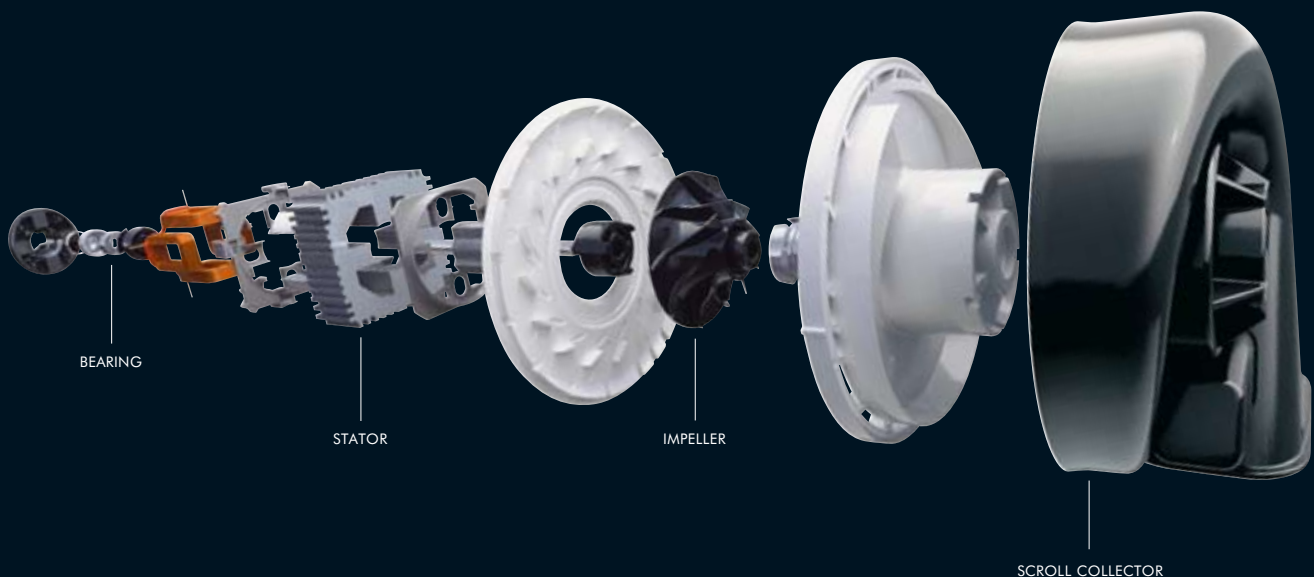

Hygienic

**The Airblade™ hand dryer is hygienic, too.
Helping to keep clean hands, clean.**

Automatic

It starts and stops automatically.
No dirty buttons to press.

No rubbing

Warm air hand dryers rely on people rubbing their hands. That just brings bacteria in the lower skin layers to the surface. With the Airblade™ hand dryer, no rubbing is required.

Clean, dry hands

Because it's so fast, people leave with dry hands – not damp ones that can spread up to 1000 times more bacteria.

Anti-microbial coating

Anti-microbial additives in external surfaces.

Only clean air

A HEPA filter removes 99.9% of bacteria from the air, before blowing it onto hands.



Test, test, test



TESTED, TESTED AND TESTED AGAIN FOR OVER 8,000 HOURS



BACTERIA FOUND IN COMPETITOR HAND DRYER AIRFLOW

Built to last

Dyson engineers and scientists spent three years developing, testing and refining the Airblade™ hand dryer. Every component was tested. Again and again. It was battered repeatedly, had cigarettes stubbed out all over it, was sprayed with chemicals and exposed to extreme temperatures. Some washrooms can be quite unforgiving.

That's why the Airblade™ hand dryer is guaranteed for five years parts and one year on-site labour.

Hygienic

NSF International, the consulting body on workplace hygiene, tested the Airblade™ hand dryer and certified it to comply with their strict requirements for a hygienic hand drying system. It's the only hand dryer compliant with NSF's Protocol P335 for hygienic hand dryers.



"The BSF welcomes Dyson's approach to promoting skin health and hand hygiene through its revolutionary hand dryer."



"The Royal Institute of Public Health considers that the Airblade™ hand dryer is a significant step forward in hand dryer technology and hygiene."



NSF Protocol P335
The Airblade™ hand dryer meets or exceeds the standards of NSF protocol P335 and is the first and only hand dryer to be NSF certified.

The problem with hand drying...

Warm air hand dryers were invented 60 years ago. Their design has changed very little since then – even the technology inside remains much the same.

Because they can use low speed airflows and energy-hungry heating elements they dry hands slowly and therefore use more power.

They work by sucking in dirty washroom air, heating it up and blowing it back onto clean hands.

Air is heated using an energy-hungry heating element.

Their motors rely on carbon brushes which can wear down.



Paper towels

Paper towels

They can be expensive to buy and dispose of. People sometimes use more than they need as well.

Roller towels are no better. The financial impact of maintaining them is high.



dyson airblade

The fastest, most hygienic hand dryer.

Touch-free operation

Intelligent infra-red sensor control for touch-free drying and minimal energy wastage.

Easy to clean

Tough, sealed ergonomic design for easy cleaning and maintenance.

Anti-microbial additives

Anti-microbial additives integrated into all external surfaces.

Robust aluminium die-cast casing

Durable casing resists chips and scratches.

HEPA filtration

Lifetime filter removes over 99.9% of bacteria from the air used to dry hands.

Over 600,000mm² of High Efficiency Particle Arrestor (HEPA) filter.

Rapid hygienic drying

Wipes hands dry with a high velocity blade of air in 10 seconds.

Thermoset plastic with a 0.3mm gap along its entire 230mm length directs air at 640km/h to dry hands.

Efficient standby mode

Standby power consumption of 1 Watt for increased energy efficiency.

Noise suppression

Precisely tuned silencing technology integrated into the motor housing and ducting to reduce air noise.

Long-life, energy efficient motor

Energy efficient 1600w Dyson Digital Motor for durability and low maintenance.

Switched reluctance motor

Only 3 moving parts, no slip rings or carbon brushes to wear out.

High compression fan

Digitally switched at up to 6,000 times per second making the compressor spin at 88,000rpm.

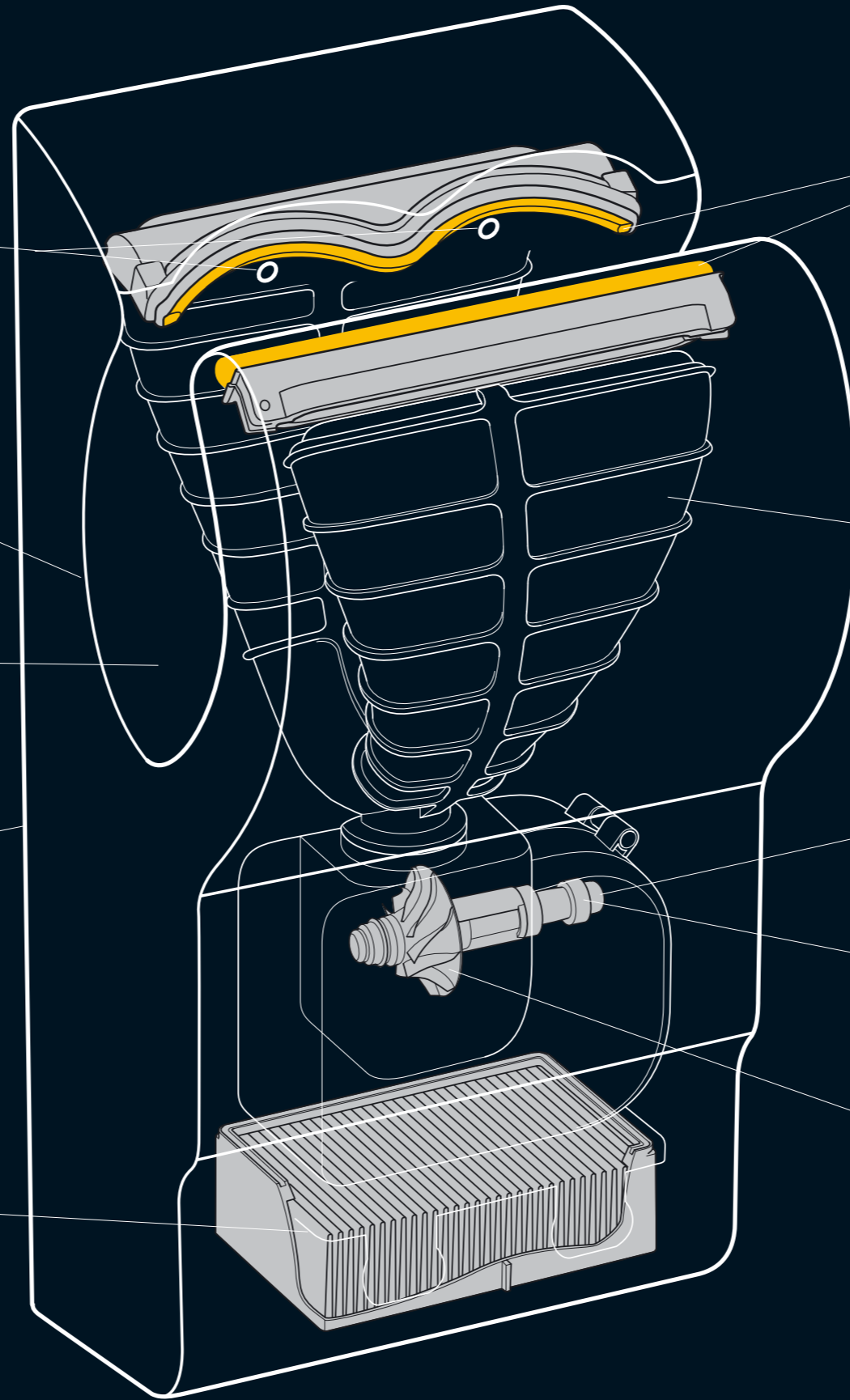

5 year guarantee

dyson airblade

Awards and certifications

The Airblade™ hand dryer has been certified for its hygiene benefits. It's also won many awards and accolades for its energy efficiency.

Most recently, the Airblade™ hand dryer won Green Product of the Year at the Sustainable Building Services Awards 2007 in London. As well as Energy Efficient Product of the Year at the 2007 British National Energy Efficiency Awards.

- National Energy Efficiency Awards
Energy Efficient Product 2007, UK
- Observateur du Design Star 2007, France

Accreditations and research partners

- NSF International certified
- Skin research validated by the
British Skin Foundation, UK
- Hygiene Research Certified by the
Royal Institute of Public Health, UK



AU 1800 239 766
dysonairblade@dyson.com.au
www.dyson.com/airblade/au

NZ 0800 397 667
dysonairblade@averyrobinson.co.nz
www.dyson.com/airblade

5 year guarantee

The Airblade™ hand dryer comes with a five year/350,000 uses guarantee covering parts and a one year on-site guarantee for labour.